



Lithium Button-Cell Battery

VER:

DATE:

3.0V

Lithium Button Battery Specification

70mAh

Model: CR1620

Prepared By/Date	Checked By/Date	Approved By/Date

Important Notice

These data sheets contain information specific to batteries manufactured at the time of its publication.

Content herein do not constitute a warranty.

Copyright @ Xtra-Power Battery .All rights reserved



Lithium Button-Cell Battery

VER:

DATE:

PRODUCT SPECIFICATION

1. Applicability: This specification is applicable to **CR1620** coin type manganese dioxide lithium battery

2. Battery type and ratings:

2.1 Battery type: **CR1620**

2.2 Nominal voltage: **3.0V**

2.3 Nominal capacity: **70mAh** (on continuous discharge at 20 °C under 30kΩ load to 2.0V end-voltage)

2.4 Outer dimensions: outer dimensions shall be as shown in **Fig1.** dimension drawing

2.5 Weight: **1.2 grams** (approx)

2.6 Terminals: **positive can** (BA stainless steel), **negative cap** (BA stainless steel)

2.7 Operating temperature range: **-20 °C ~ +60 °C**

2.8 Storage temperature range: **0 °C ~ +35 °C**

2.9 Storage humidity range: **45 % ~ 85 %**

3. Battery performance:

3.1 Dimensions:

Dimensions of batteries when tested in accordance with Subparagraph 4.4(1) shall be as shown in Fig1 dimensions drawing.

3.2 Appearance:

Batteries shall have no deformation, dent, stain, leakage and camber or burr on their sealing members, which may adversely affect their appearance, performance and commercial value.

There shall be no coatings or other foreign objects on the surface of terminals which may adversely affect actual use or performance of batteries.

3.3 Characteristics:

(1) Open-circuit Voltage:

Open-circuit voltage of batteries when tested in accordance with Subparagraph 4.4(3) shall meet the requirement set forth in Table 1.

(2) Closed-circuit Voltage:

Closed-circuit voltage of batteries when test in accordance with Subparagraph 4.4(4) shall meet the requirements set forth in Table 1.



Lithium Button-Cell Battery

VER:

DATE:

[Table 1]

Test Items	Temperature	Initial *	After 12 Months	Remarks
Open-Circuit Voltage	$20 \pm 2^{\circ}\text{C}$	3.1V To 3.4V	3.1V To 3.4V	
	$0 \pm 2^{\circ}\text{C}$	3.1V To 3.4V	3.0V To 3.4V	
Closed-Circuit Voltage	$20 \pm 2^{\circ}\text{C}$	3.1V To 3.4V	3.1V To 3.4V	Load Resistance 30k Ω , 8 Sec.
	$0 \pm 2^{\circ}\text{C}$	3.1V To 3.4V	3.0V To 3.4V	

(Note) * "Initial " Means Performance Values Measured Within One Month After Delivery.

(3) Service Life:

Service life of batteries when tested in accordance with Subparagraph 4.4(5) shall meet the requirements set forth in Table 2.

[Table 2]

Test Items	Temperature	Initial *	After 12 Months	Remarks
Service Life	$20 \pm 2^{\circ}\text{C}$	830 Hrs. or Longer	780 Hrs. or Longer	Continuous Discharge Under 30k Ω Load to 2.0V End-Voltage
	$0 \pm 2^{\circ}\text{C}$	740 Hrs. or Longer	700 Hrs. or Longer	

(4) Service Life after storage at high temperature:

Service life of batteries when tested in accordance with Subparagraph 4.4(6) shall meet the requirements set forth in Table 3.

Test Item	Storage temperature	Storage Period	Requirement	Remarks
Service Life After Storage At High Temperature	$60 \pm 2^{\circ}\text{C}$	20 Days	780 Hrs Minimum	Continuous Discharge At $20 \pm 2^{\circ}\text{C}$ Under 30k Ω Load To 2.0V End-Voltage After Storage.

(5) Leakage Characteristics:

Batteries when tested in accordance with Subparagraph 4.5(1) shall have no leakage.

[Table 4]

Test Item	Requirement	Test Conditions
Leakage Characteristics	No Leakage	Temperature: $45 \pm 2^{\circ}\text{C}$, Relative Humidity: 75% Storage: 30 Days Shall Be Inspected By Visual Means



Lithium Button-Cell Battery

VER:

DATE:

(6) Self-Discharge:

Self-discharge of batteries when tested in accordance with Subparagraph 4.5(2) shall be as set forth in Table 5.

[Table 5]

Test Item	Requirement	Test Conditions
Self-discharge	5% or Below	Continuous Discharge Under 30 kΩ Load To 2.0V End-voltage After 12 Months Storage At 20°C. (To Obtain From The Mean Value Of The Same Lot)

4. Testing:

4.1 Temperature and Humidity:

Unless otherwise specified elsewhere, tests shall be conducted at ordinary temperature ($20 \pm 2^{\circ}\text{C}$) and ordinary humidity ($65 \pm 5\% \text{RH}$).

4.2 Storage of Test Specimen Batteries:

Specimen batteries to be tested shall be kept at the ambient temperature of 25°C or below and at the relative humidity of 75% or below.

4.3 Measuring Instruments and Devices:

(1) Outer micrometers specified in JJG26-95, dial gauges specified in JIS B 7503, and vernier calipers specified in JJG30-92 or those having equal or better accuracy shall be used.

(2) DC Voltmeters:

The tolerance shall be $\pm 0.01\text{V}$ and the input resistance rating shall be $10\text{M}\Omega$ or more.

(3) Load Resistance:

Load resistance shall include resistance throughout external circuits, and its tolerance shall be $\pm 0.5\%$.

4.4 Test Methods:

(1) Dimensions:

Dimension shall be measured with instruments specified in Subparagraph 4.3(1) above, provided that either one or both sides of such instruments shall be insulated in measuring the overall height of the batteries.

(2) Appearance:

Appearance of batteries shall be inspected by visual means.

(3) Open-circuit Voltage:

Test specimen batteries shall be kept for 8 hours or longer at the ambient temperature specified in Table 1, and then the voltage between both terminals shall be measured at the same ambient temperature with a voltmeter as specified in Subparagraph 4.3(2).

(4) Closed-circuit Voltage:

Test specimen batteries shall be kept for 8 hours or longer at the ambient temperature specified in Table 1. and then the voltage between both terminals shall be measured with a voltmeter as specified in



Lithium Button-Cell Battery

VER:

DATE:

subparagraph 4.3(2) while the specified load resistance is connected between both terminals at the same ambient temperature as specified above; provided that the measured value shall be based on meter reading taken 8 seconds after the circuit is closed.

(5) Service Life:

Test specimen batteries shall be kept for 8 hours or longer at the ambient temperature specified in Table 2. and shall then be continuously discharged at the same ambient temperature and through the specified load resistance. The discharge shall be continued until the terminal voltage of the test specimens falls below the discharge end-point voltage of 2.0V, and the time during which the terminal voltage has been maintained equal to and above the discharge end-point voltage shall be taken as the service life.

(6) Service Life after high-temperature storage:

Test specimen batteries, after having been stored at the temperature and period specified in Table 3, shall be kept for 12 hours or longer at ordinary temperature ($20 \pm 15^\circ\text{C}$) and at ordinary humidity ($65 \pm 20\%RH$) and shall then be continuously discharged through the specified load resistance at ambient temperature of $20 \pm 2^\circ\text{C}$. The discharge shall be continued until the terminal voltage falls below the discharge end-point voltage of 2.0V, and the time during which the terminal voltage has been maintained equal to and above the discharge end-point voltage shall be taken as the service life.

4.5 Other Tests:

Tests specified below shall be conducted as required. Except as specified in this paragraph.

Test methods be in accordance with the provisions of Paragraph 4.4.

(1) Electrolyte Leakage Test:

Test specimen batteries shall be examined for electrolyte leakage while they are kept at ordinary temperature and at ordinary humidity after having been stored at the temperature, humidity and period specified in Table 4.

(2) Self-Discharge:

Test specimen batteries which have been stored for 12 month at the ambient temperature of $20 \pm 2^\circ\text{C}$ and at the relative humidity of $65 \pm 20\%$ shall be tested for service life in accordance with the method specified in Subparagraph 4.4(5). Self-discharge shall be determined in the following manner:

$$\text{Self-discharge rate (\%)} = \frac{X1 - X2}{X1} \times 100\%$$

X1: Average initial discharge life of batteries of the same lot

X2: Average discharge life after storage



Lithium Button-Cell Battery

VER:

DATE:

5. Markings:

5.1 Markings on batteries:

- (1) Battery type: **CR1620**
- (2) Brand of battery: Xtra-Power
- (3) Polarity: + (- shall not be indicated)
- (4) Manufacturing marks: The year and month of production shall be marked on the negative (-) terminal side

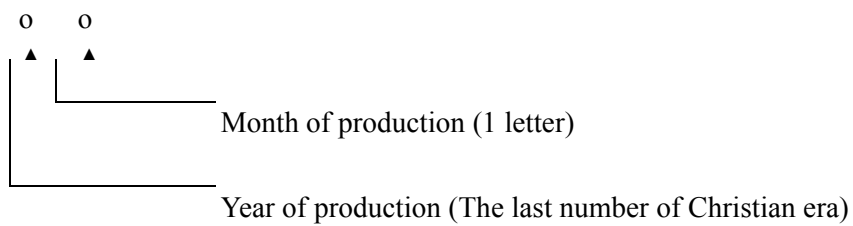

[Example] 18 August 2001

month of production.

- January to September ---- 1- 9

- Oct, Nov, Dec -----X, Y, Z

6. Packaging:

6.1 Product CR1620

6.2 20 pcs, tray

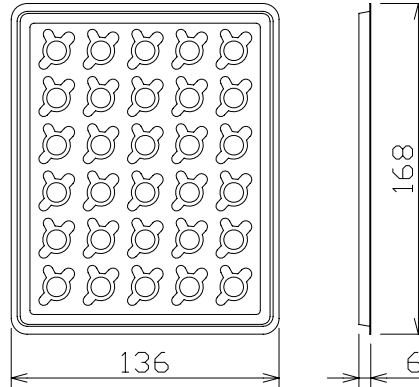
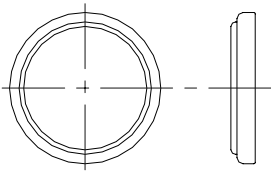

6.3 300 pcs, shrink packing

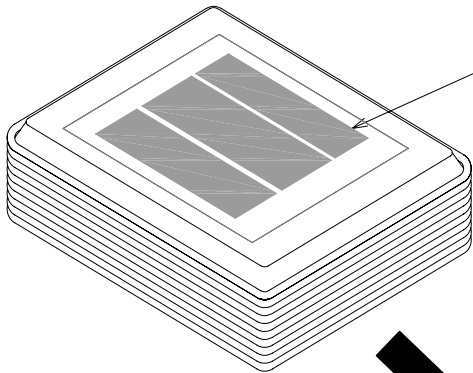

Inspection conformation

6.4 7200 pcs, corrugated board case

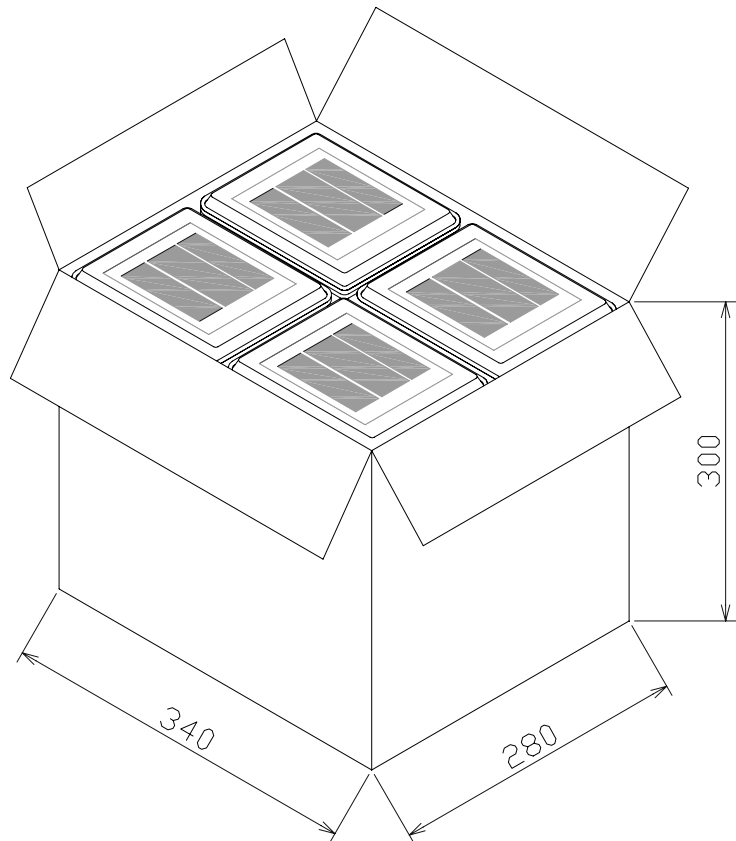

Fig1. Dimension drawing of CR1620 lithium battery

