



Zinc Manganese Dioxide Battery

VER:

DATE:

1.5V

Zinc Manganese Coin type Battery Specification

18mAh

Model: LR66

Prepared By/Date	Checked By/Date	Approved By/Date

Important Notice

These data sheets contain information specific to batteries manufactured at the time of its publication.

Content herein do not constitute a warranty.

Copyright @ Xtra-Power Battery. All rights reserved



Zinc Manganese Dioxide Battery

VER:

DATE:

PRODUCT SPECIFICATION

1. Applicability: This specification is applicable to **LR66** coin type zinc manganese dioxide battery.

SPECIFICATION

1. Cross Reference :

IEC	JAPAN	Ray-O-Vac	U.S.A SWITZERLAND	GERMANY	H.K PRODUCTS
LR66	LR626	RW329	377	V377	AG4

- 2. Chemical System :** Zinc-Manganese Dioxide (Potassium Hydroxide Electrolyte)
- 3. Nominal Voltage :** 1.50V
100mAh (continuously discharge at 20±2°C under 22k Ω load to 0.9V end-point voltage)
- 4. Standard Capacity :**
- 5. Approximate Weight :** 0.28g
- 6. Dimensions & Structure :** Dimensions & structure of the cell are shown in the attached Fig. 1.
- 7. Terminal Materials :**
 - Negative : Ni plated/Fe/Cu plated or gold plated steel
 - Positive : Ni plated steel



Zinc Manganese Dioxide Battery

VER :

DATE :

8. Characteristics :

Characteristics of the cell are shown in the following table.

Items	Storage	Characteristics	Conditions
8.1 Electric Characteristics			
Open-Circuit Voltage	Initial	1.510V or higher	DC Voltmeter: The tolerance is $\pm 0.005V$ and the input resistance is $1M\ \Omega$ or more.
	After 12 months	1.500V or higher	
Closed-Circuit Voltage	Initial	1.500V or higher	DC Voltmeter : Same as above. Load Resistance : $22k\ \Omega$, 0.8Sec.
	After 12 months	1.490V or higher	
8.2 Service Output			
Service Life 22k Continuous Discharge	Initial	330 hrs or longer	Discharge Resistance : $22k\ \Omega$ End-Point Voltage : 0.9V
	After 12 months	298 hrs or longer	
8.3 Electrolyte Leakage Proof Characteristics			
Electrolyte leakage on overdischarge	There are no bulging or deformation of cells in excess of maximum dimensions shown in attached Fig. 1 by 0.2mm or more. There are no visible electrolyte leakage.		Temperature : $20\pm 2^{\circ}C$ Humidity : $(65\pm 20)\%RH$ Load Resistance : $22k\ \Omega$ Overdischarge Time : 48hrs (discharge after having reached specified end-point voltage)

9. Discharge Curve :

Load Resistance : 22k Ω

End-Point Voltage: 0.9V

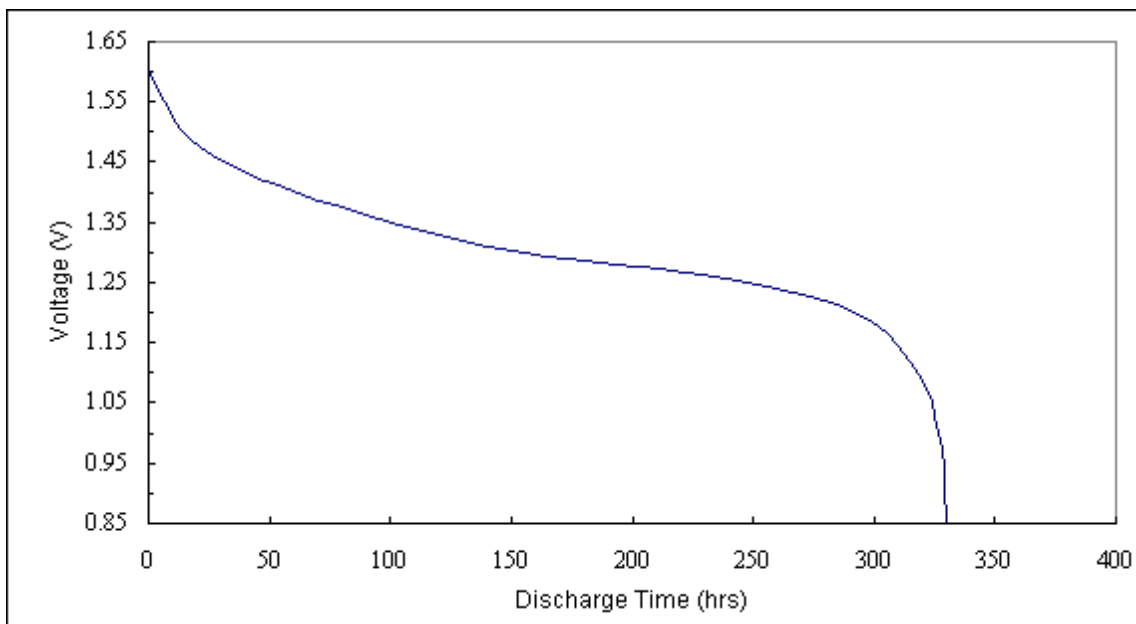

10. Markings on Product :

- (1) Battery Type : L626
- (2) Brand :
- (3) Polarity : "+" at the bottom ("--" not indicated)
- (4) Other specified markings

11. Caution for Use :

- (1) Since the button cell is not manufactured for recharging, there are risks of electrolyte leakage or causing damage to the device if the cell is charged.
- (2) The button cell shall be installed with its "+" and "--" sign according to the instruction shown on the applied device.
- (3) Short-circuiting, heating, disposing of in fire, or disassembling the button cell shall be prohibited.

12. Warranty :

12 months shelf life after delivery.

L626 DIMENSIONS & STRUCTURE

Dimensions (in mm) :

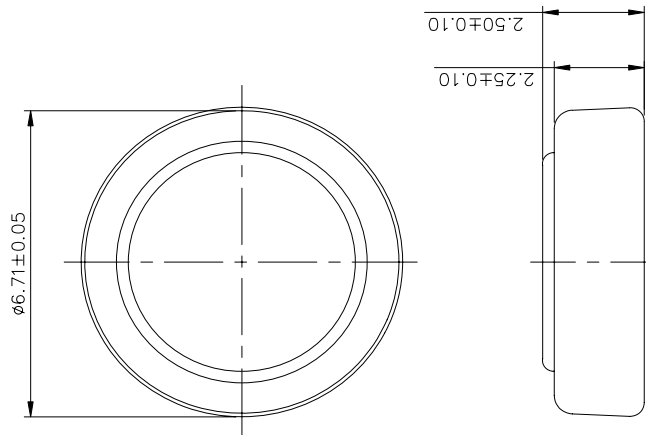

Structure :

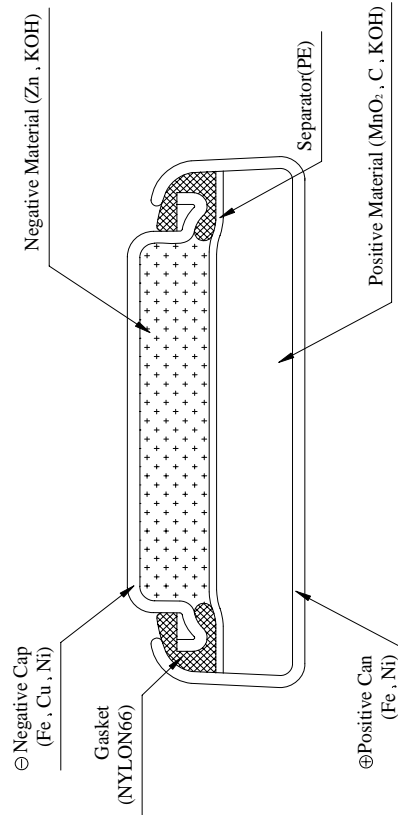

Fig. 1