



# Zinc Manganese Dioxide Battery

VER:

DATE:

**1.5V**

## Zinc Manganese Coin type Battery Specification

**13mAh**

**Model: LR60**

Prepared By/Date	Checked By/Date	Approved By/Date

### Important Notice

These data sheets contain information specific to batteries manufactured at the time of its publication.

Content herein do not constitute a warranty.

Copyright @ Xtra-Power Battery .All rights reserved



# Zinc Manganese Dioxide Battery

VER:

DATE:

## PRODUCT SPECIFICATION

**1. Applicability:** This specification is applicable to **LR60** coin type zinc manganese dioxide battery.

### **SPECIFICATION**

**1. Cross Reference :**

IEC	JAPAN	Ray-O-Vac	U.S.A SWITZERLAND	GERMANY	H.K PRODUCTS
LR60	----	RW320	364	V364	AG1

- 2. Chemical System :** Zinc-Manganese Dioxide ( Potassium Hydroxide Electrolyte )
- 3. Nominal Voltage :** 1.50V  
13mAh ( continuously discharge at 20±2°C under 22kΩ load to 0.9V end-point voltage )
- 4. Standard Capacity :**
- 5. Approximate Weight :** 0.28g
- 6. Dimensions & Structure :** Dimensions & structure of the cell are shown in the attached Fig. 1.
- 7. Terminal Materials :**
  - Negative : Ni plated/Fe/Cu plated or gold plated steel
  - Positive : Ni plated steel



# Zinc Manganese Dioxide Battery

VER :

DATE :

## 8. Characteristics :

Characteristics of the cell are shown in the following table.

Items	Storage	Characteristics	Conditions
<b>8.1 Electric Characteristics</b>			
Open-Circuit Voltage	Initial	1.510V or higher	DC Voltmeter: The tolerance is $\pm 0.005V$ and the input resistance is $1M\ \Omega$ or more.
	After 12 months	1.5000V or higher	
Closed-Circuit Voltage	Initial	1.500V or higher	DC Voltmeter : Same as above. Load Resistance : $22k\ \Omega$ , 0.8Sec.
	After 12 months	1.490V or higher	
<b>8.2 Service Output</b>			
Service Life $22k\ \Omega$ Continuous Discharge	Initial	240hrs or longer	Discharge Resistance : $22k\ \Omega$  End-Point Voltage : 0.9V
	After 12 months	216hrs or longer	
<b>8.3 Electrolyte Leakage Proof Characteristics</b>			
Electrolyte leakage on overdischarge	There are no bulging or deformation of cells in excess of maximum dimensions shown in attached Fig. 1 by 0.2mm or more. There are no visible electrolyte leakage.		Temperature : $20\pm 2^{\circ}C$ Humidity : $(65\pm 20)\%RH$ Load Resistance : $22k\ \Omega$ Overdischarge Time : 48hrs (discharge after having reached specified end-point voltage)

## 9. Discharge Curve :

Load Resistance : 22k  $\Omega$ 

End-Point Voltage: 0.9V

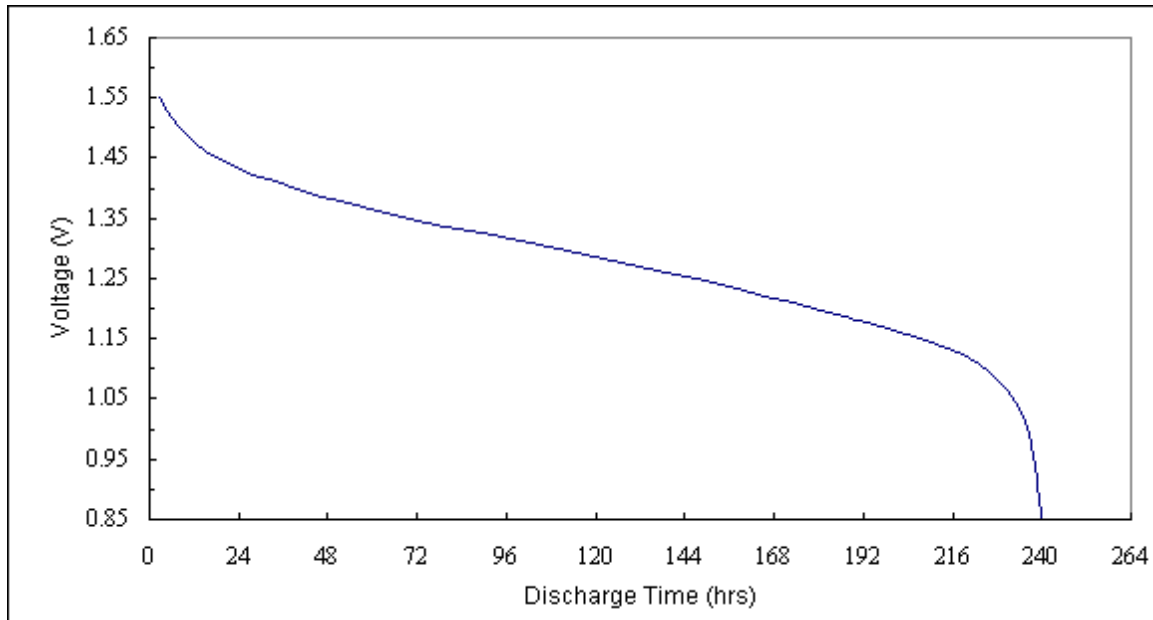

## 10. Markings on Product :

- (1) Battery Type : L621
- (2) Brand :
- (3) Polarity : "+" at the bottom ( "--" not indicated )
- (4) Other specified markings

## 11. Caution for Use :

- (1) Since the button cell is not manufactured for recharging, there are risks of electrolyte leakage or causing damage to the device if the cell is charged.
- (2) The button cell shall be installed with its "+" and "--" sign according to the instruction shown on the applied device.
- (3) Short-circuiting, heating, disposing of in fire, or disassembling the button cell shall be prohibited.

## 12. Warranty :

12 months shelf life after delivery.

## L621 DIMENSIONS & STRUCTURE

Dimensions ( in mm ) :

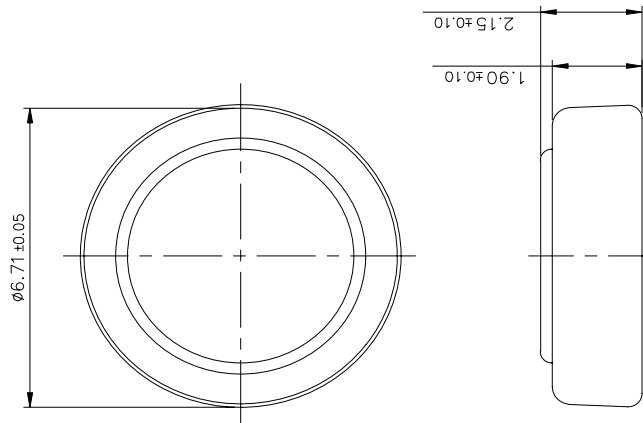

Structure :

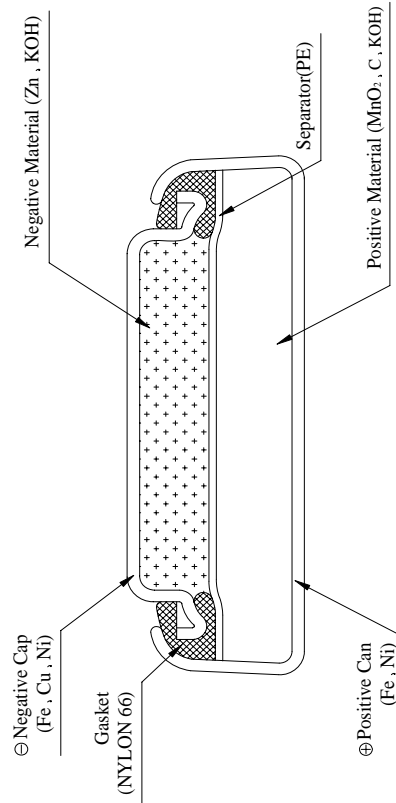

Fig. 1