



Lithium-ion Cylindrical Battery

VER:

DATE:

Rechargeable 3.0V

Li-ion Battery

13000mAh

Specification

Model: [RCR-V3](#)

Prepared By/Date	Checked By/Date	Approved By/Date

Important Notice

These data sheets contain information specific to batteries manufactured at the time of its publication.

Content herein do not constitute a warranty.

Copyright @ Xtra-Power Battery .All rights reserved



Lithium-ion Cylindrical Battery

VER:

DATE:

---CONTENTS---

1. SCOPE	Page2
2. BATTERY PACK SPECIFICATION.....	Page2
3. STANDARD TEST CONDITIONS	Page2
4. APPEARANCES	Page3
5. ELECTRICAL CHARACTERISTICS	Page4
6. TEMPERATURE ADAPTABILITY	Page5
7. DESTROY ADAPTABILITY	Page6
8. 8.1 PCM SPECIFICATION	Page7
8.2 PCM STANDARD	Page7
8.3 PRINCIPLE DRAWING	Page8
9. CAUTIONS IN USE	Page8
10. Dimension	Page9



Lithium-ion Cylindrical Battery

VER:

DATE:

1. SCOPE

This specification describes the related technical standard and requirements of the rechargeable Li-ion battery pack supplied by Xtra-Power.

Battery packs produced with the GPB14430 cell will meet the specification.

2. BATTERY PACK SPECIFICATION

ITEMS	SPECIFICATION	REMARK
Model	RCRV3	
Constant Voltage	3.0V	No load of specification 3.7V
Nominal Capability	1300mAh	
Adaptable for	/	
Cell Type	GPB14430	
Dimensions	51.86(±0.1)*28.47(±0.1)*14.23(±0.1)mm	
Color	/	
Weight	38.6(±0.1)g	

3. STANDARD TESTING CONDITIONS (No Load)

ITEMS	REGISTER		
Standard charge	CC/CV model, constant voltage4.2V, constant current0.2C, end current 0.01C		
General charge.	CC/CV model, constant voltage4.2V, constant current0.5C, end current0.01C		
Max charge	CC/CV model, constant voltage4.2V, constant current 1C, end current 0.01C		
Standard discharge	Constant current 0.2C, end voltage3.0V		
General discharge	Constant current 0.5C, end voltage 3.0V		
Max discharge	Constant current 1C, end voltage 3.0V		
Environment temperature	Charge	0 -- +45℃	
	Discharge	-20℃ -- +60℃	
	Storage temperature	One month	-20℃ -- +55℃
		Three months	-20℃ -- +45℃
		One year	-5℃ -- +30℃
	General temperature	20℃ ± 5℃	
	Atmospheric pressure	86 -- 106Kpa	
Relative humidity	45% -- 85%		



Lithium-ion Cylindrical Battery

VER:

DATE:

4. APPEARANCES

ITEMS	TEST CONDITION	REQUIRE
APPEARANCE	Under light lamp 40W	Shall be free noticeable flaws breaks, age, Discoloration, deformation, uneven, and other Defects which impair the value of the commodity

5. ELECTRICAL CHARACTERISTICS

ITEMS	TEST CONDITION	REQUIRE
Complete Charge	The battery is charged with constant current 1CmA and constant voltage 4.2v until the charging current is less than 0.01CmA. The longest charging time is less than 3 hours.	
Initial capacity	The capacity measured after the battery is discharged with constant current 0.2C until the voltage reaches 3.0V cut-off in one hour after complete charge.	$\geq 1300\text{mAh}$
Cycle life	The capacity measured after 400 cycles of complete charge and discharge at 1C current to 3.0V cut-off.	Capacity more than 80% of Initial capacity
Impedance	Internal resistance measured at 1KHz after complete charge.	$\leq 140\text{m}\Omega$



Lithium-ion Cylindrical Battery

VER:

DATE:

6. TEMPERATURE ADAPABILITY

ITEMS	TEST CONDITION	REQUIRE
High temperature discharge	After complete charge, at 60°C , discharging current 0.2C to 3.0V-END discharge.	No explosion, fire, or smoke. Discharge efficiency $\geq 85\%$.
High temperature cycle	At $(55 \pm 2)^\circ\text{C}$, discharging current 1CmA and charging constant voltage 4.2V, cycle test three times	No explosion, fire, or smoke. Charge efficiency $\geq 90\%$
High temperature exposure	After relative charge, all batteries being tested are stored in chamber of 150°C for 0.5 hour. After taking the batteries out of the chamber, all the batteries are visually examined.	No explosion, fire, or smoke.
Low temperature discharge	After complete charge. At -20°C , discharging current 0.2CmA to 3.0V-END discharge.	No explosion, fire, or smoke. Discharge efficiency $\geq 80\%$.
Low temperature cycle	At $(-20 \pm 2)^\circ\text{C}$, discharging current 0.2CmA and charging constant voltage 4.2V, cycle test three times	No explosion, fire, or smoke. Charge efficiency $\geq 85\%$



Lithium-ion Cylindrical Battery

VER:

DATE:

7. DESTROY ADAPTABILITY

ITEMS	TEST CONDITION	REQUIRE
E. S. D TEST	To apply 33Ω resistance and stasis Electricity energy of 1500PF capacitor. To All terminals (+, -) apply the below for 10 times each, 1. Contact : $\pm 8KV$ 2. Air : $\pm 15KV$	No malfunction. No damage.
Vibration Test	Subject to 1 hour 10-55Hz 3.5mm amplitude Vibration for any direction at shipment (complete packing) state. Then test discharge and rated charge at $25\pm 2^{\circ}C$.	No explosion. fire ,or Smoke. No leakage or damage and Good battery (to the phone) Condition.
Drop Test	Drop test battery 1.2m above steel board of more than 10mm thickness. One time drop each for 6 surface, 4 ride direction of a battery pack	No leakage or damage and Good battery (to the phone) condition. No explosion, fire or Smoke. Discharge time Less than 50 minute.



Lithium-ion Cylindrical Battery

VER:

DATE:

8.1 PCM SPECIFICATION

ITEMS	TEST CONDITION
Over charge protection	The battery should be charged under 9.0V/1C. The charging should be shut off when the internal cell voltage becomes more than the specified protection voltage.
Over discharge protection	The battery should be discharged with 1C, The discharging should be shut off when the internal cell voltage becomes less than the specified protection voltage.
Short protection	After rated charge, (+) and (-) terminals are connected with 10m mental resistor or equivalence.
Current consumption	Ordinary current consumption: consumption current of the protection circuit when internal cell voltage reaches 7.4V (Max:10 μ A)
General current consumption	Shut off current consumption: consumption current of the Protection circuit when internal cell voltage reaches 6.0v (Max:3 μ A)

8.2 PCM STANDARD

Symbol	Name	Conditions	MIN.	TYP.	MAX.	Unit
VDET1	Over-Charge detect voltage		4.30	4.35	4.40	V
VHVS1	Over-Charge reset voltage		4.1	4.125	4.15	V
TVDET1	Output delay of over-Charge	C3=0.01uF, VDD=3.6, V->4.4V	700	1000	1300	ms
VDET2	Over-discharge detect voltage		2.238	2.3	2.463	V
TVDET2	Output delay of over-Discharge	VDD=3.6V, V->2.4V	14	20	26	ms
VDET3	Excess current detect voltage		0.18	0.2	0.22	V
TVDET3	Output delay of Excess current	VDD=3.0V	8	12	16	ms
IDD	Supply current	VDD=3.9V, V-=0V	3		6	μ A
ISTANDBY	Standby current		0.4nA		0.2	μ A

8.3 (PCM Diagram)

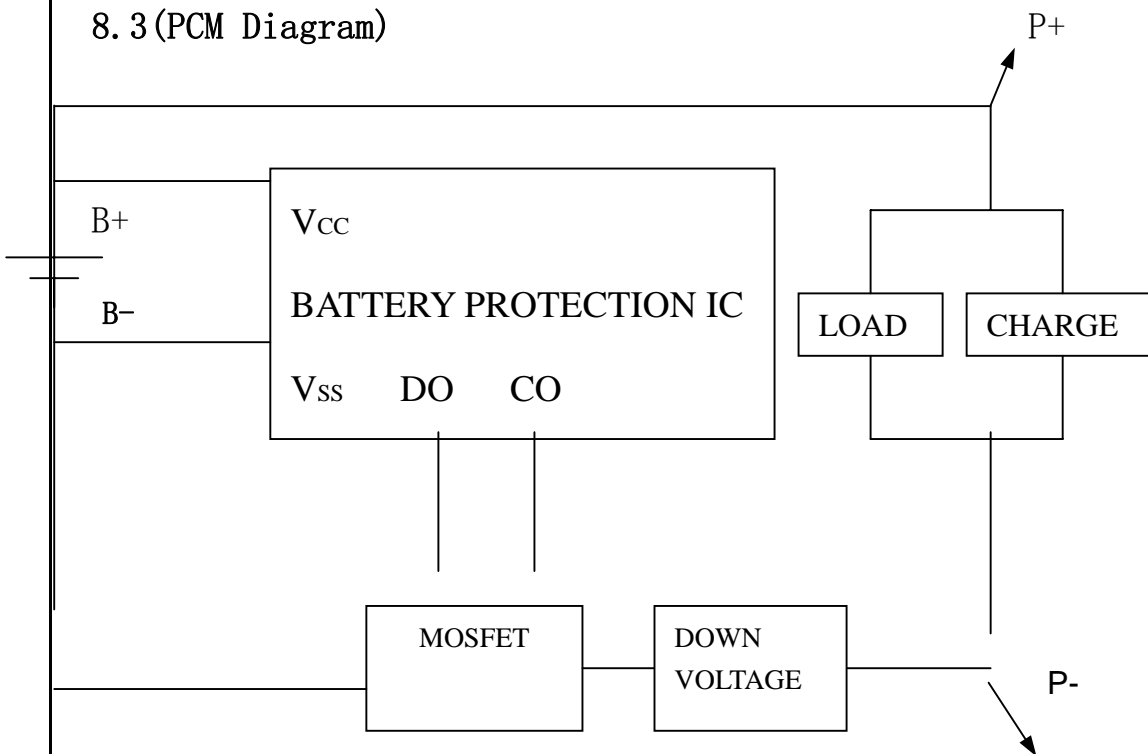

9. CAUTIONS IN USE

To ensure proper use of the battery please read the manual carefully before using it.

. Handling

- Do not expose to, dispose of the battery in fire.
- Do not put the battery in a charger or equipment with wrong terminals connected.
- Avoid shorting the battery
- Avoid excessive physical shock or vibration.
- Do not disassemble or deform the battery.
- Do not immerse in water.
- Do not use the battery mixed with other different make, type, or model batteries.
- Keep out of the reach of children.

. charge and discharge

- Battery must be charged in appropriate charger only.
- Never use a modified or damaged charger.
- Do not leave battery in charger over 24 hours.

. storage

- Store the battery in a cool, dry and well-ventilated area.

. disposal

- Regulations vary for different countries. Dispose of in accordance with local regulations.

10. Dimension:

